



NON-INSULATED FIRE RATED ACCESS DOOR

Model KRP-250FR

For Walls Only



KARP ASSOCIATES, INC.
 54-54 43rd Street, Maspeth, NY 11378
 (718) 784-2105 - Phone
 (718) 784-9169 - Fax

DATE

SPECIFICATIONS

GENERAL SCOPE:

Classified access frame and fire door assembly 1 1/2 hour "B" Label Underwriters Laboratories File #10806.

CONSTRUCTION:

1. Frame shall be 4 piece welded 16 gage steel with anchor straps.
2. Door shall be 16 gage steel.
3. Hinge shall be exposed, continuous piano hinge.
4. Door shall have automatic closure, be self-latching and contain interior latch release.
5. Latches shall be bolt type, operated by either a ring turn or flush key device (all keyed alike), or access doors shall be prepared for mortise (or rim cylinder) locks which shall be supplied by others.
6. Finish shall be prime coat of rust inhibitive electrostatic powder, baked grey enamel. Stainless steel doors shall have #4 satin finish.

STANDARD SIZES

DOOR SIZE H X W (IN.)	WALL/CEILING OPENING (IN.)	NUMBER OF LATCHES	SHIP WT. (LBS.)
8 x 8	8 3/8 x 8 3/8	1	5.1
12 x 12	12 3/8 x 12 3/8	1	8.5
14 x 14	14 3/8 x 14 3/8	1	9.8
16 x 16	16 3/8 x 16 3/8	1	11.7
18 x 18	18 3/8 x 18 3/8	1	13.8
24 x 24	24 3/8 x 24 3/8	1	20.5
30 x 22	30 3/8 x 22 3/8	1	22.6
30 x 30	30 3/8 x 30 3/8	1	28.2
36 x 24	36 3/8 x 24 3/8	2	28.5
36 x 36	36 3/8 x 36 3/8	2	39.6

PROJECT DATA					
Project Name:					
Architect:					
Contractor:					
Agent/Customer Name:					
Tagging Instructions:					
Special Instructions:					

PROJECT SCHEDULE					
Qty.	H	W	No. of Latches	Finish	Remarks

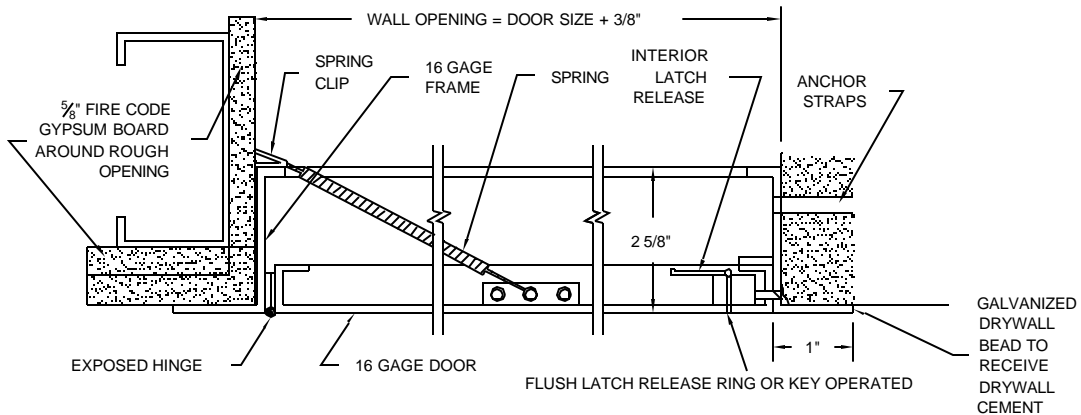
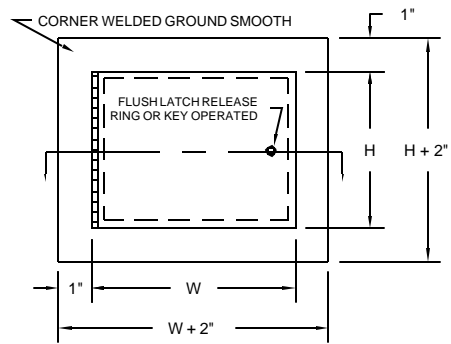

SECTION A-A